

Diagramme des cas d'utilisation :



Diagramme d'exigences:



Diagramme de définition de bloc :

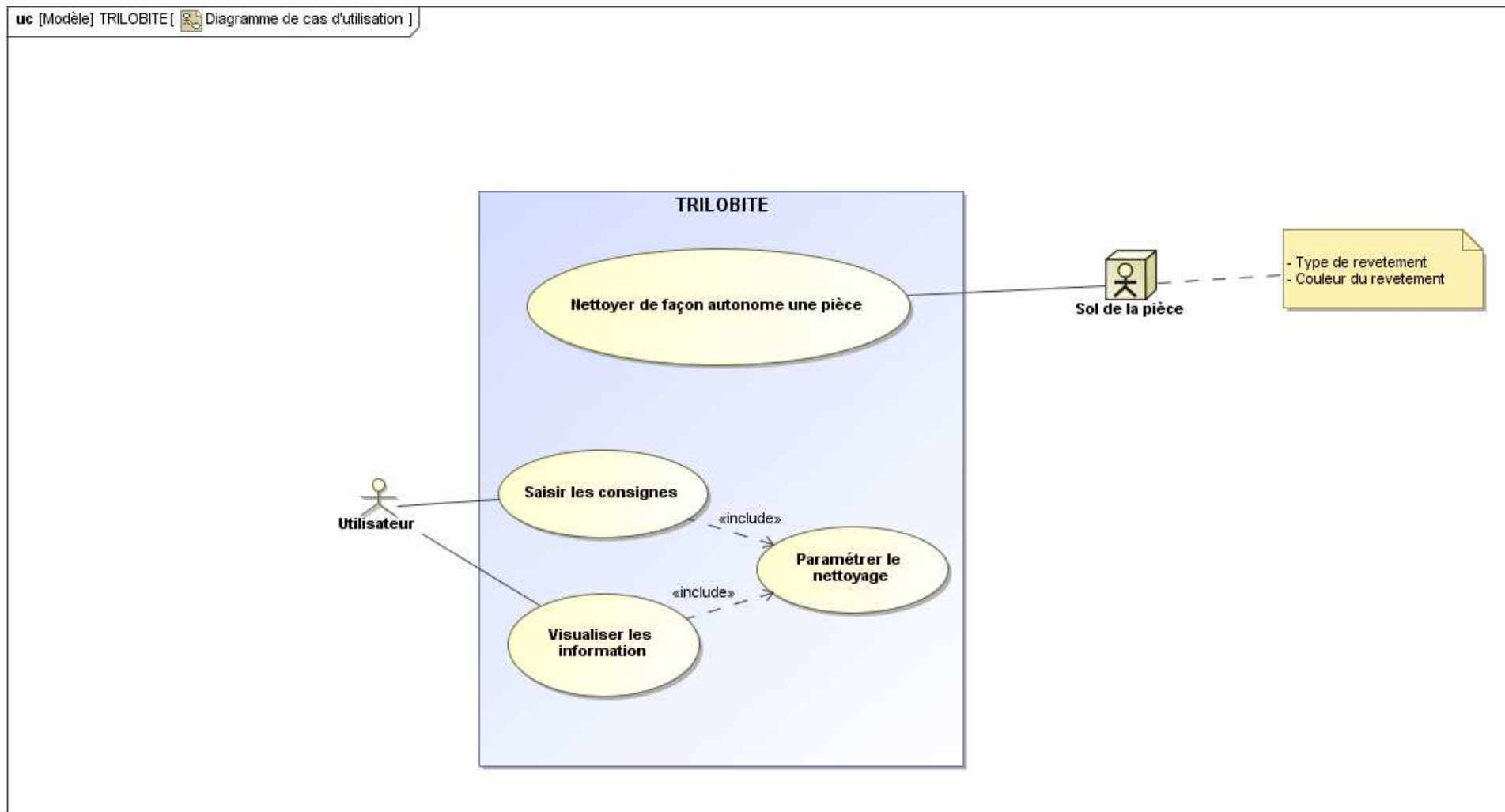

Diagramme de bloc interne : Trilobite

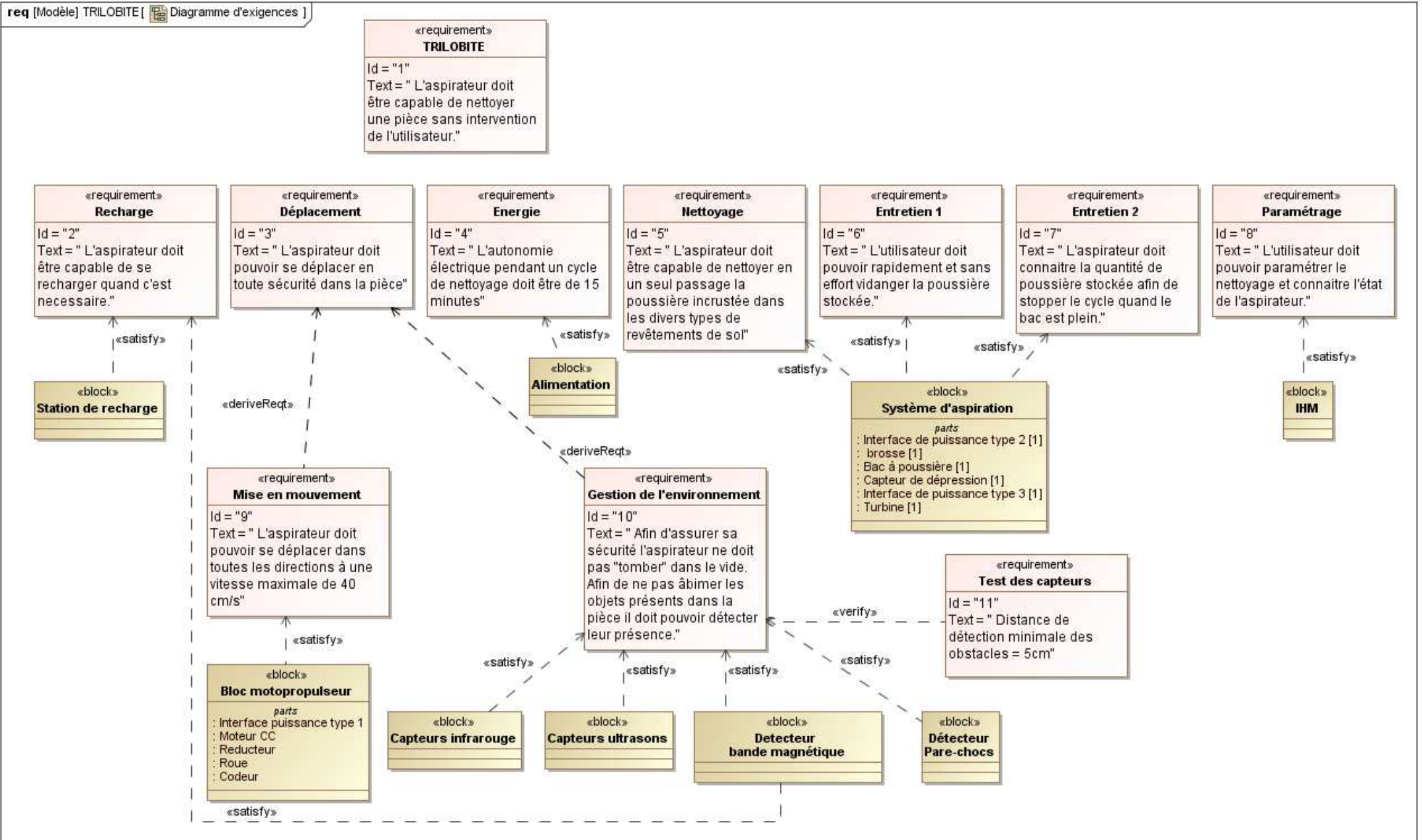

Diagramme de bloc interne : Bloc motopropulseur

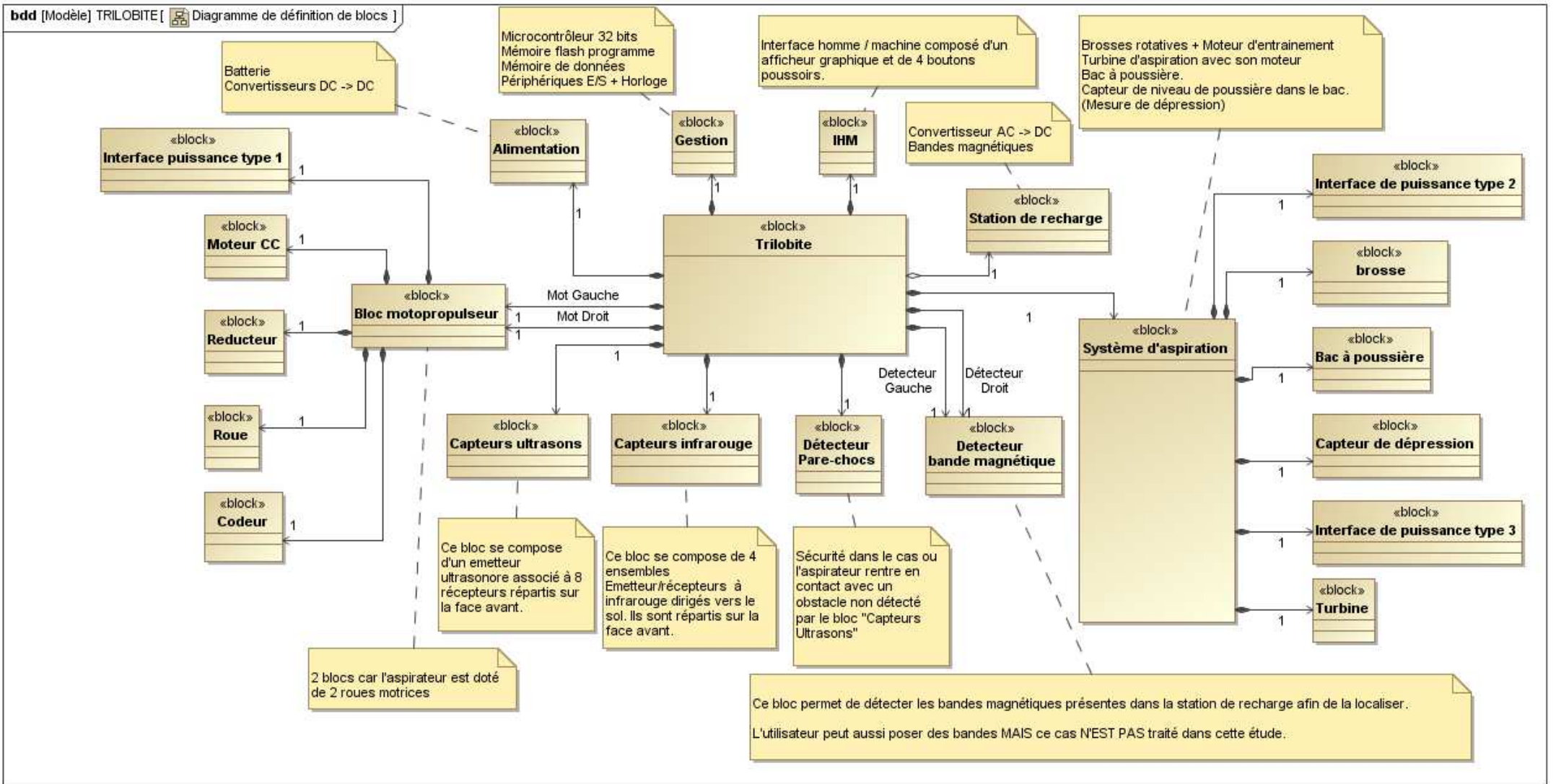

Diagramme de bloc interne : Système d'aspiration

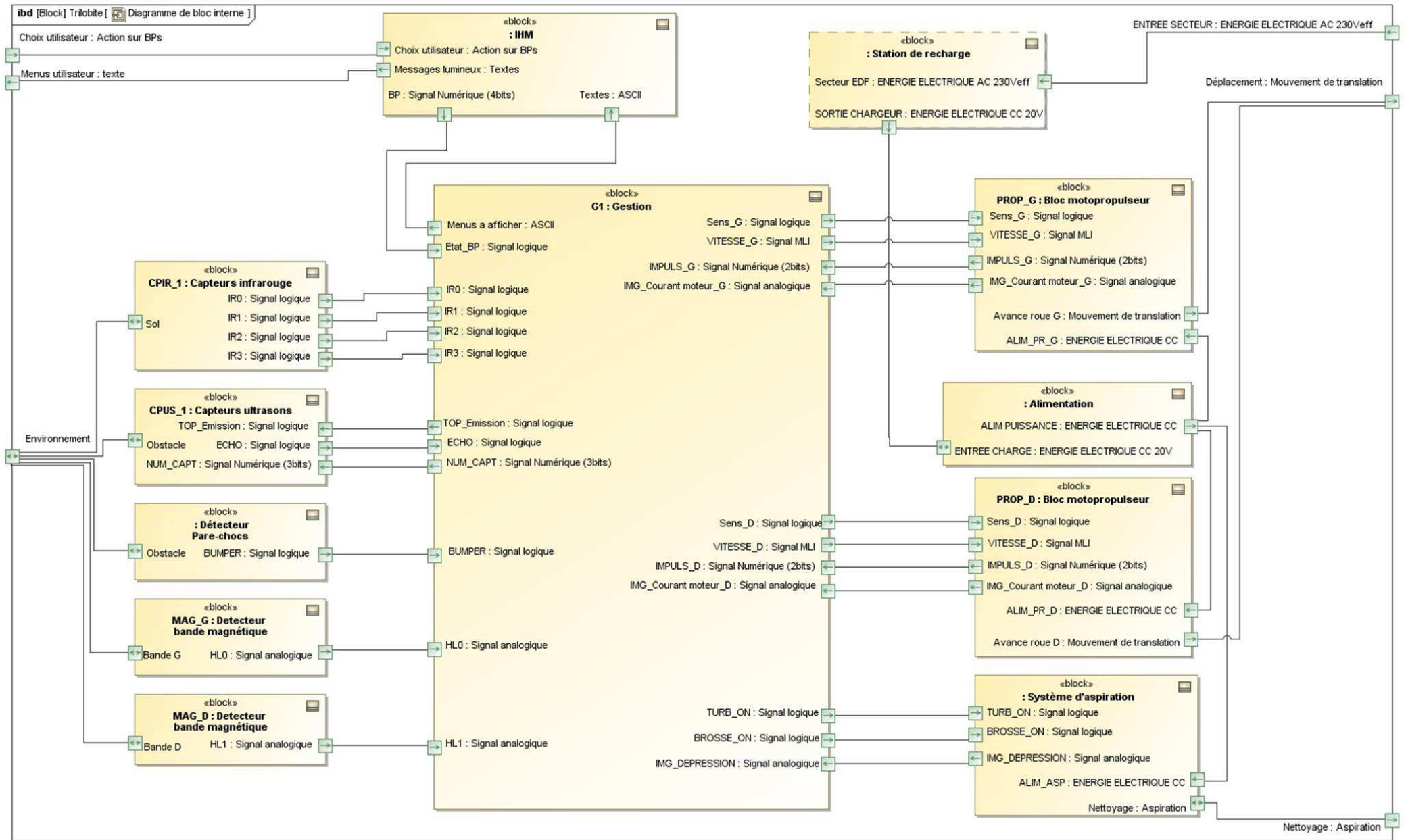

Diagramme d'états du bloc alimentation :

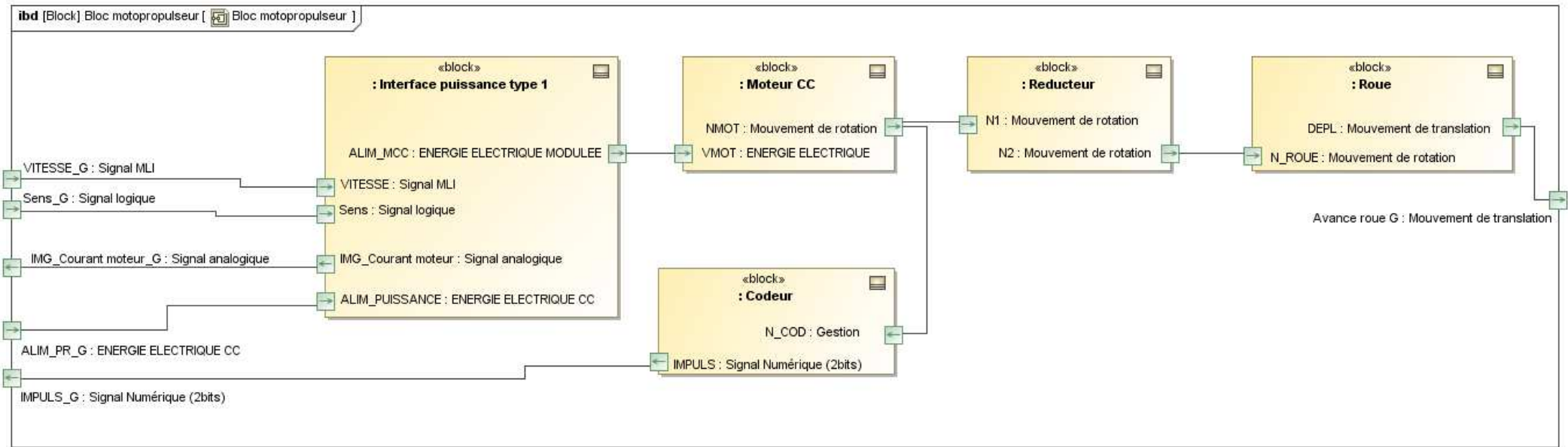

Diagramme de séquence : Sélection du mode d'aspiration

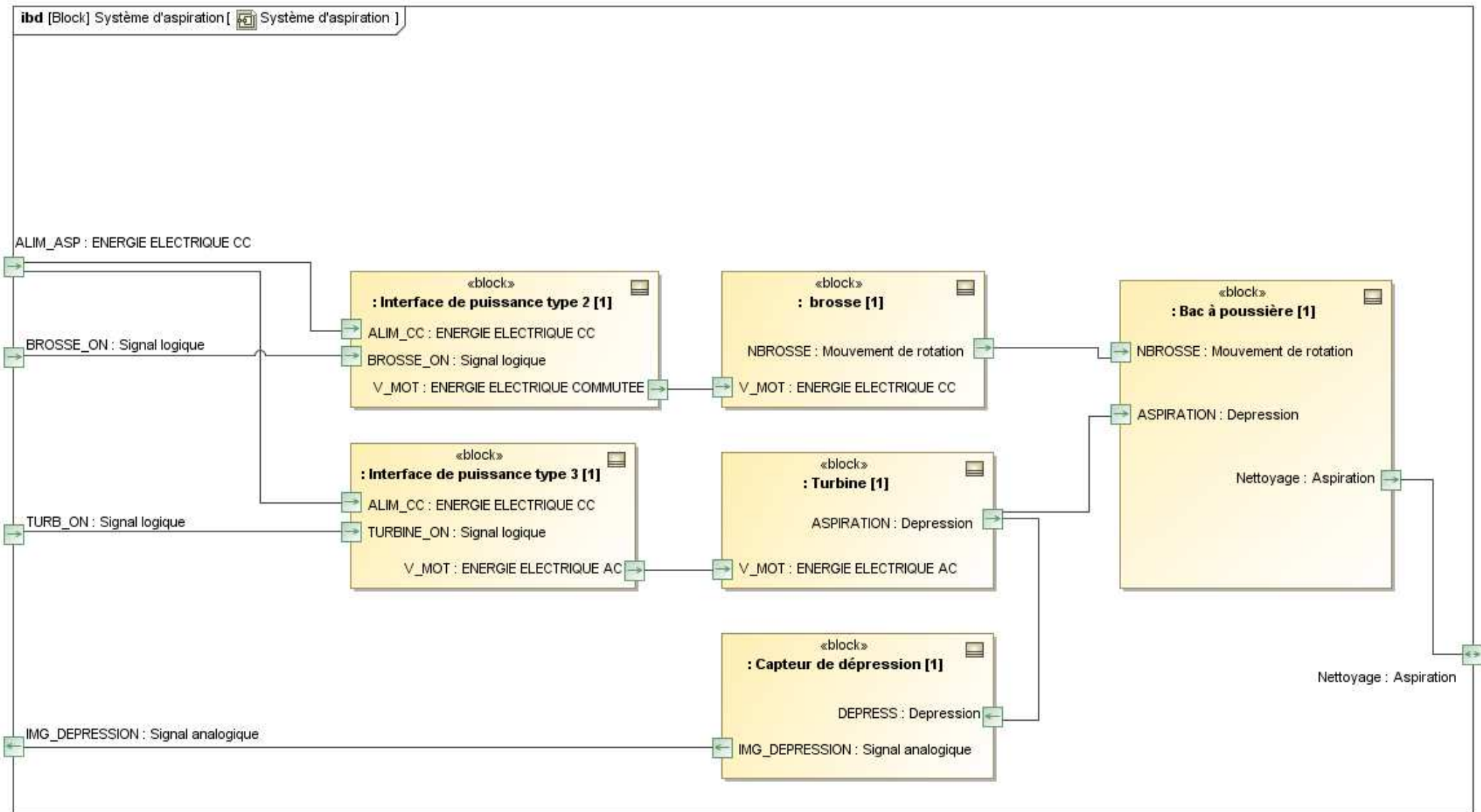

Diagramme de séquence : Aspiration en mode normal

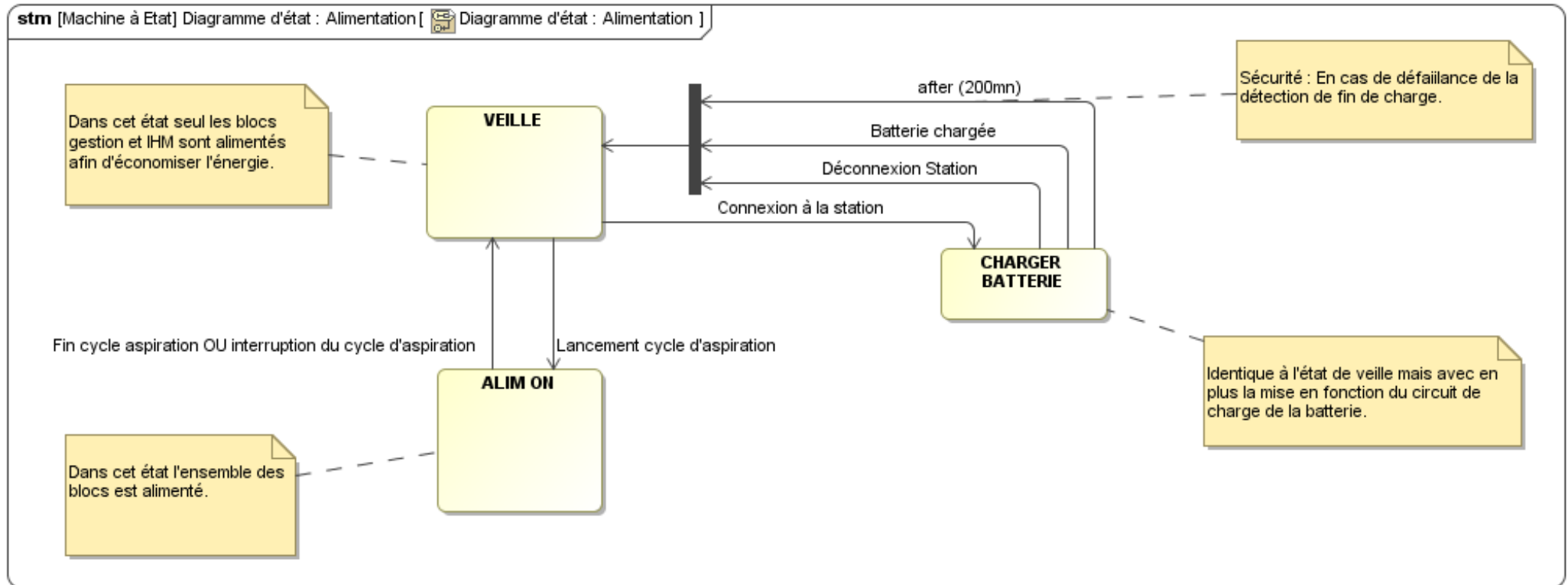

Diagramme de séquence : Aspiration en mode rapide

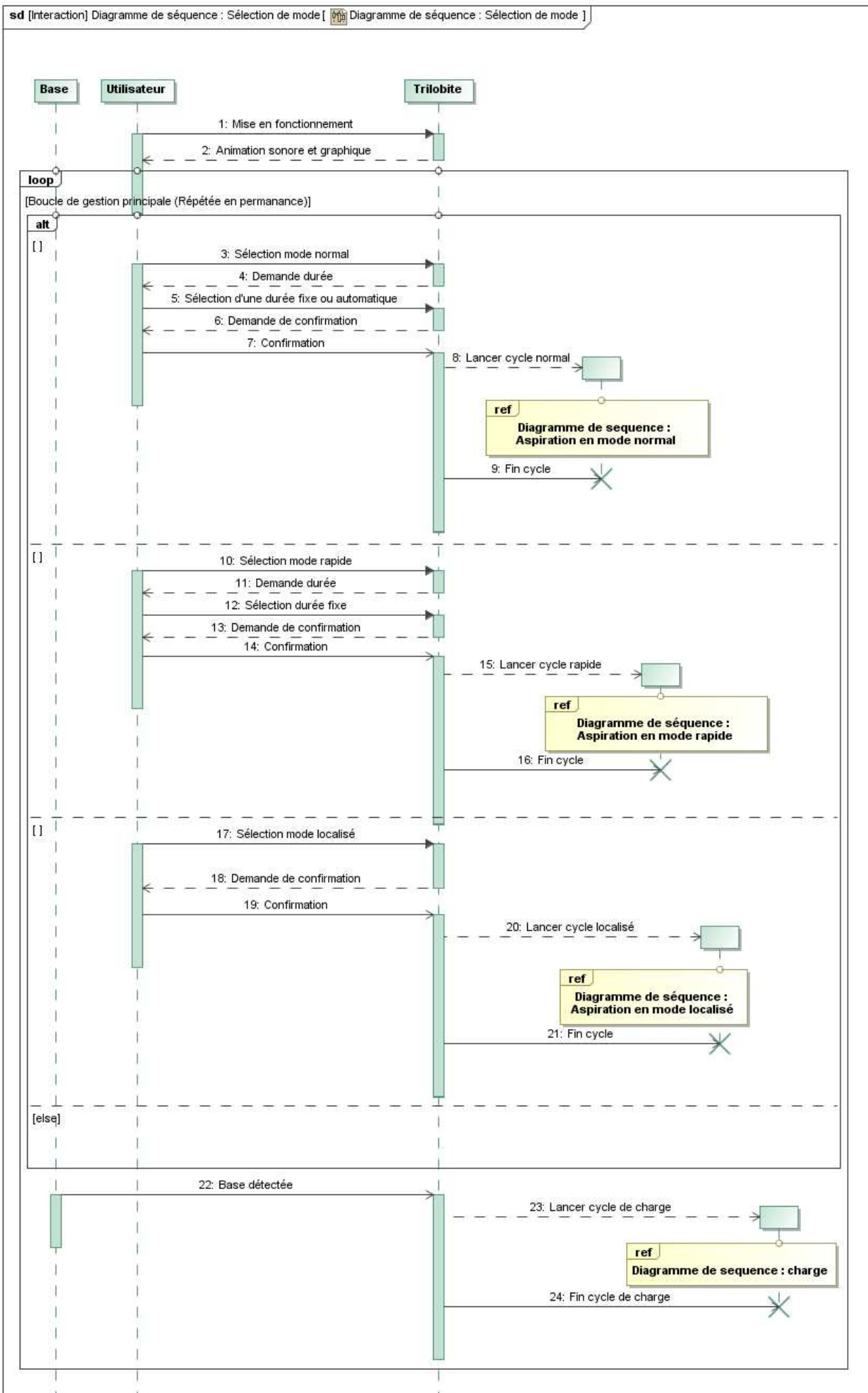

Diagramme de séquence : Aspiration en mode localisé

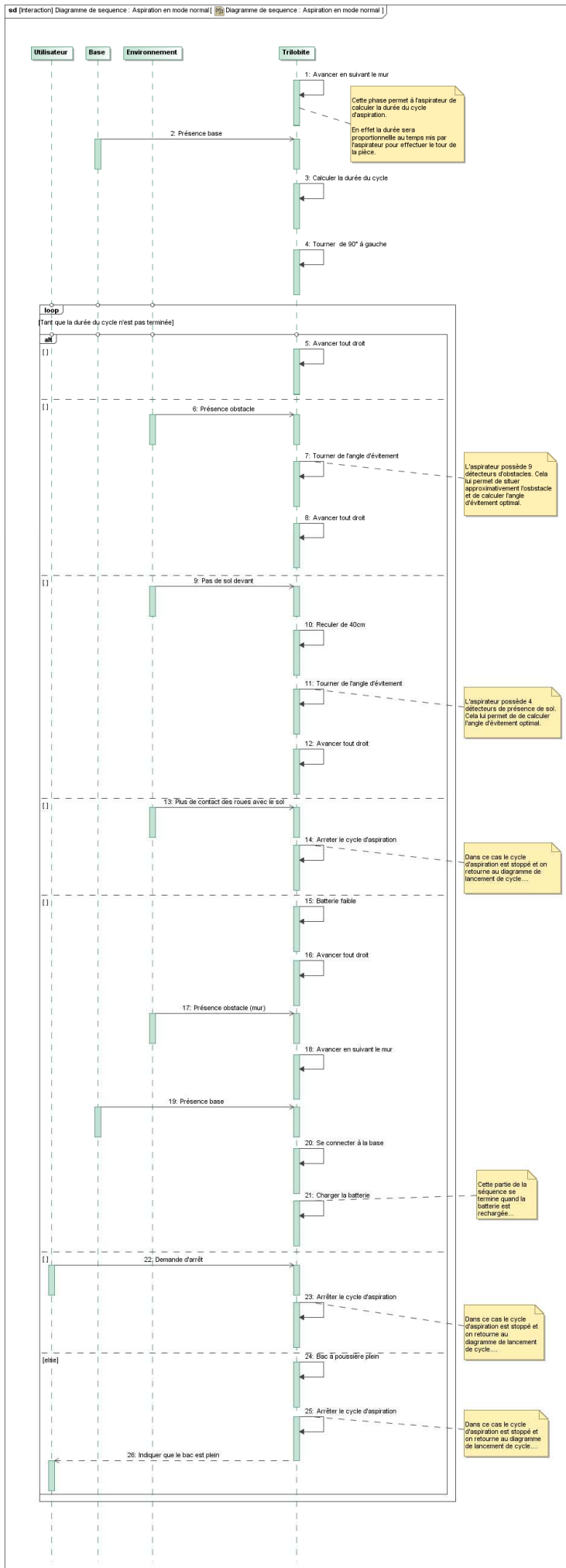
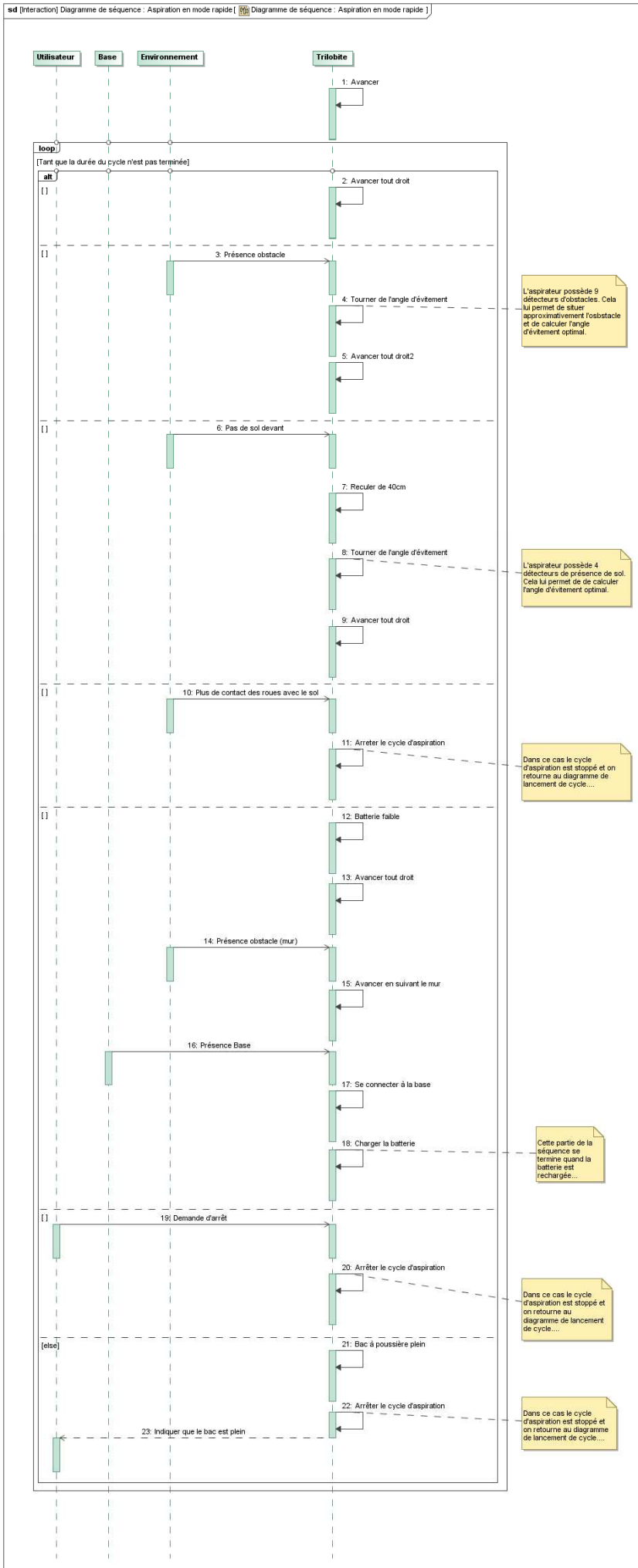